

GRAND LIGHTING™

M20D DOWNLIGHT LED GOBO PROJECTOR

Table of Contents 2

INTRODUCTION 3

 Before You Begin 3

 Contents 3

 Safety Information 3

 An Overview of Your Light 3

OPERATION 4

 Installation Guide 4

 Focusing 4

GOBOS 5

 Gobo Specifications 5

 Changing / Installing Your Gobo 5

TECHNICAL SPECIFICATIONS 6

 Photometric Data 6

 Power supply | Light source 6

 Fixture Dimensions 6

SERVICE AND WARRANTY 7

 Standard Warranty 7

 Service, Warranty Claims and Returns 7

BEFORE YOU BEGIN

- Open the contents of the box and check that the goods have not been damaged during transit.

NOTE: You must notify us of any suspected damage within 48 hours upon receiving the goods in order for us to follow up with the freight company.

- Check that you have received the correct goods including projector and gobo (if ordered as a package).
- If you ordered your projector and gobo as a package deal, your gobo should already be installed in the projector ready for use.

Any claims, returns or incorrect supply must be lodged within 48 hours of receiving the goods.

CONTENTS

- M20D Downlight LED Gobo Projector
- External Power Supply
- Gobo (if ordered as a package)
- Manual

SAFETY INFORMATION

Most units will come supplied with a gobo, check to see the projector works for the proposed location before proceeding with the install.

Non-IC Rated Driver, Non IC-Rated luminaire. To be installed by a licenced electrician to the relevant standard. Commercial non residential use only.

Use only with specified approved driver for the supplied model.

Always disconnect the unit from power when changing the gobo.

WARNING – This Luminaire is not suitable for installation in locations where thermal insulation is present, or may be reasonably expected to be installed in the future, or where this is a likelihood of other combustibile material, e.g. leaves or vermin debris, etc. collecting on or around the luminaire.

It is not suitable for domestic installations or installation in residential areas of non-domestic installations (residential institutions, hotels, boarding houses, hospitals, accomodations houses, motels, hostels and the like).

Risk of Fire or overheating if the clearance distances are compromised.

AN OVERVIEW OF YOUR LIGHT



INSTALLATION GUIDE

Minimum hole size for cutout is 86mm, while the coverplate is 109mm, so keep your hole size well within this.
Fold back the spring clips to push unit up through your hole.

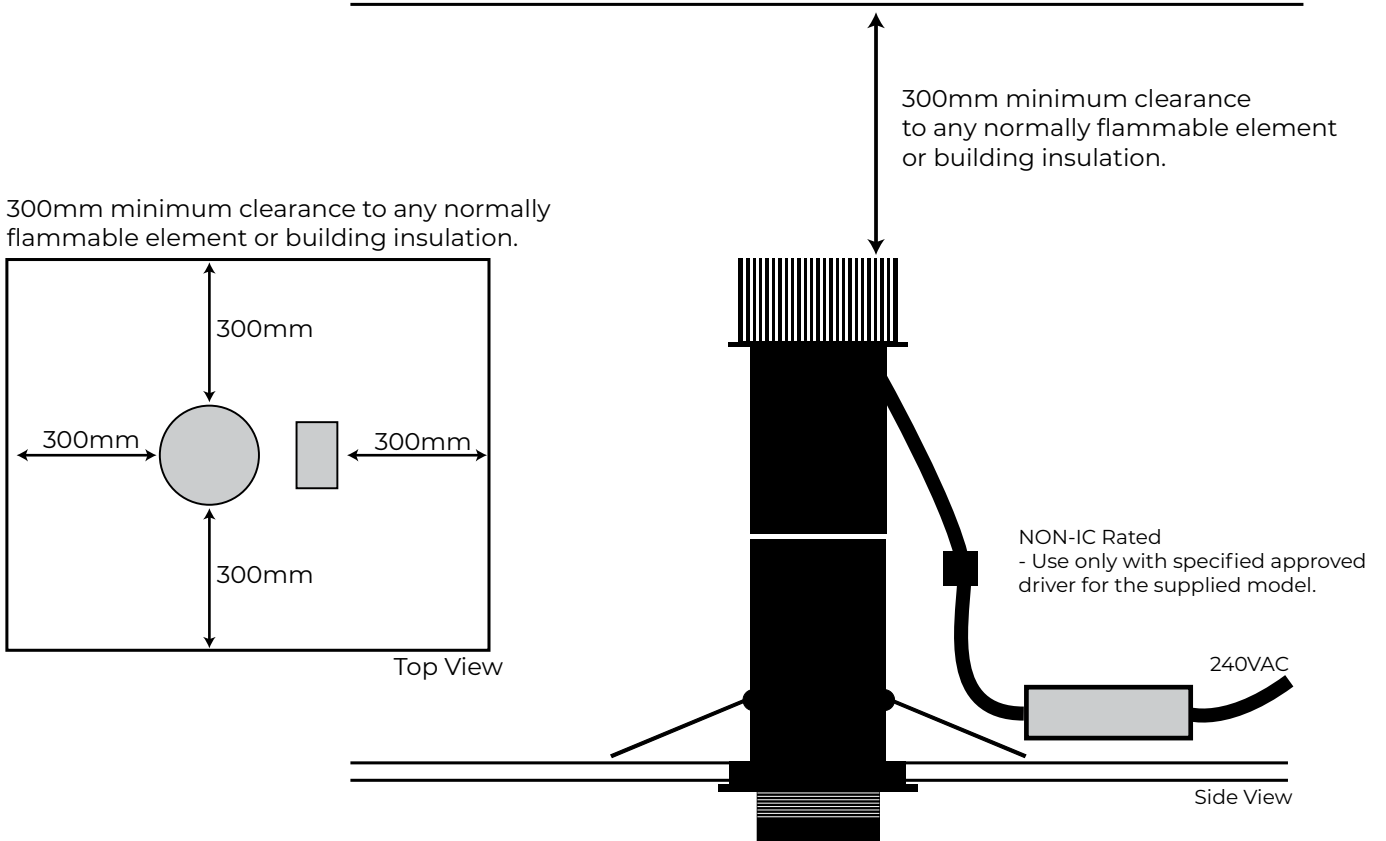

FOCUSING

To focus simply rotate the front lens (as indicated below) until you achieve good focus.



GOBO SPECIFICATIONS

- Suitable material: Metal or Borosilicate glass
- Gobo size: 37.5mm outside diameter +0/-0.3mm
- Maximum image diameter: 28mm
- Maximum thickness: up to 5.0mm

If in doubt please contact Gobotech - www.gobotech.com.au to confirm the gobo specifications for the fixture model you have quoting the serial number.

CHANGING / INSTALLING YOUR GOBO

The gobo is situated roughly half way along the body where the arrow shows.

To change the gobo, hold the back and the front of the unit and unscrew it where the arrows shows.

Take care not to unscrew the rear heatsink by mistake.

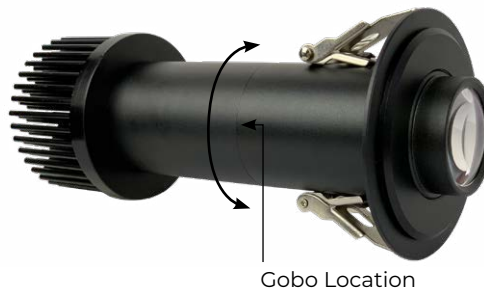

Once the front half of the unit is removed you will see where the gobo is mounted into the gobo holder, held in with a spring circlip. If there is a gobo already mounted in the light begin by removing the metal circlip which is holding the gobo in place. Swap out the gobo for your new one and do not forget to replace the metal circlip.

Make sure the circlip is pushed down so that the gobo is sitting flat, if not you will struggle to focus evenly on the gobo.

Glass gobos have a reflective mirror side and a black non reflective or white matt surface. **Glass Gobos are not reversible, they MUST be inserted with the reflective side facing the lamp.**

See diagram below showing the order of inserting the gobo into the light.

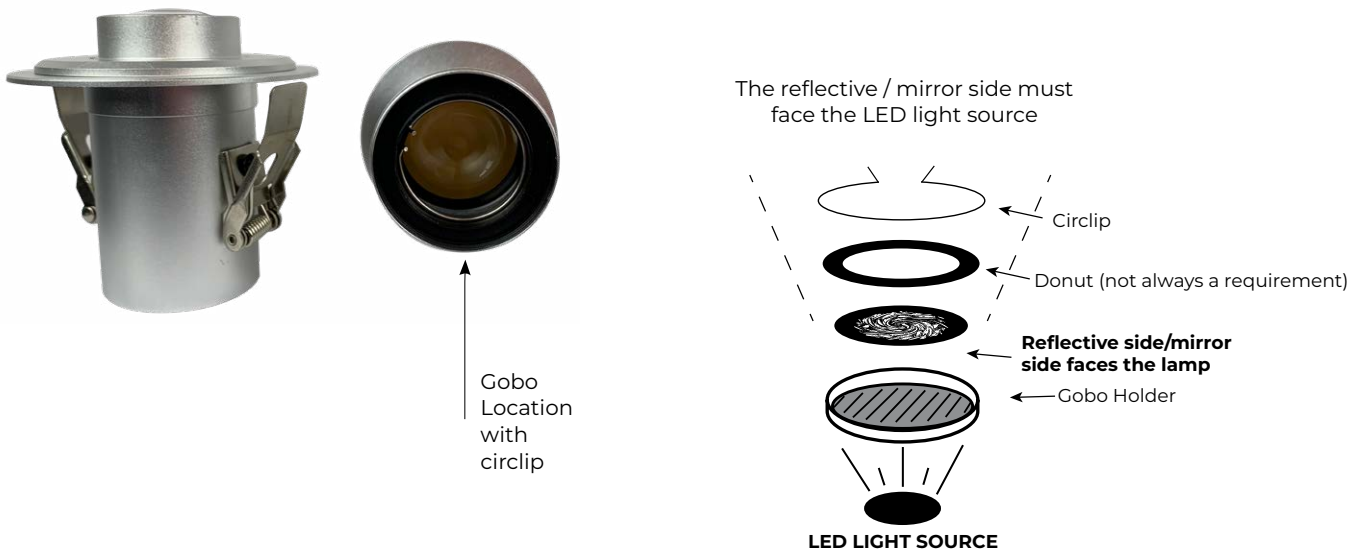

PHOTOMETRIC DATA

| | M20 | | | | STANDARD LENS | | |
|-------------------------|------|------|------|------|---------------|------|------|
| Projection Diameter (m) | 0.79 | 0.98 | 1.18 | 1.38 | 1.57 | 1.77 | 1.97 |
| Luminance (lux) | 2280 | 1459 | 1013 | 744 | 570 | 450 | 365 |
| Projection Distance (m) | 2.0 | 2.5m | 3.0 | 3.5 | 4.0 | 4.5 | 5.0 |

Lux values indicated are not peak values, which may be brighter. We give average lux readings taken under actual tests.

POWER SUPPLY | LIGHT SOURCE

- Power Supply Input Voltage: 220-240V AC
- Average Power Consumption: 25Watts
- Australian standard 3 pin plug 240V AC
- 22W 50,000 hr LED
- Cool White LED standard (unless ordered with Warm White)
- The Grand Lighting M20D Downlight is supplied and matched with a driver meeting all Australian regulatory requirements for non IC rated commercial installations

FIXTURE DIMENSIONS

- Length: 210mm (excluding lens)
- Height: 109mm
- Weight: 500g (with powersupply)

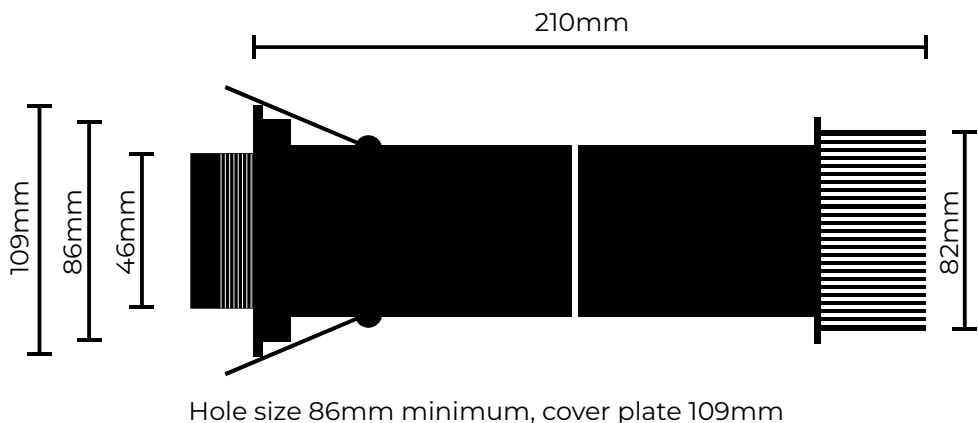

STANDARD WARRANTY

The standard warranty applies only to Grand Lighting products sold by Gobotech Pty Ltd or its authorised resellers, or country distributors. "Standard Warranty Period" means the warranty period applicable under the standard warranty being a period of 24 months from the original date of purchase of the Grand Lighting product(s) unless specifically noted and agreed to otherwise. This warranty also applies to drivers and power supplies that Gobotech have matched and sold with the Grand Lighting product.

Gobotech Pty Ltd or Grand Lighting will not be held responsible for any loss, damage, cost or expense incurred as a result of the installation or removal of any Grand Lighting product for any reason nor does this warranty cover any Grand Lighting product that has become defective due to an accident, act of god, improper installation, power surge, unreasonable use, improper service or unauthorised modification or adjustment of drivers or other causes not arising out of defects in material and workmanship. Normal wear and effects of weather that do not affect the safety or operation of the light are not covered by this warranty.

The warranty provided by us under this document is a "Return to Base" warranty. This means that the product has to be returned to us in order to receive a repair or replacement.

In the event that Grand Lighting is unable to replace or repair any defective Grand Lighting product under the warranty it will use reasonable endeavours to provide an alternative of similar specification and quality. Whilst reasonable endeavours will be taken to match the light quality, LED bin and/or colour temperature of the LED's used for any replacements, it may not always be possible to do so, due to the age of the product, changes in the LED suppliers product specification and availability. In these circumstances Grand Lighting will use reasonable endeavours to offer the closest alternative available.

Replacement parts provided under the warranty are warranted on the same terms and for the remainder of the warranty period of the Grand Lighting products they are replacing or in which they are installed.

Gobotech guarantees that Grand Lighting products are free from defects in materials or workmanship under normal use during the standard warranty period.

During the standard warranty period, Gobotech will, (following prompt written notice of the issue(s) and a reasonable period for investigation) at its discretion, repair or replace either the whole Grand Lighting product or any part of it that Gobotech deems to be defective as a result of a material or manufacturing fault. Gobotech will not be in any way liable under the standard warranty in respect to any Grand Lighting product that:

- 1) Was not originally installed in accordance with:
 - a) The installation instruction supplied with, or printed on, the Grand Lighting product or published on the Grand Lighting website (www.grandlighting.com.au)
 - b) The standards of good practice.
- 2) Was not installed in suitable environmental conditions (including but not limited to ambient temperature, moisture level and air flow for that particular Grand Lighting product);
- 3) Has been altered or modified in any way by third parties not authorised by Gobotech to do so;
- 4) Has been subject to misuse (including but not limited to incorrect operation by the user or connection to or operation with an unsuitable power supply);
- 5) Has been previously repaired by a person other than an authorised representative of Gobotech

The standard warranty period will only be valid if the date of purchase is confirmed by an official invoice issued at the time of purchase.

SERVICE, WARRANTY CLAIMS AND RETURNS

In order to make a claim under the warranty and receive the Return Authorisation Form, please contact:

Gobotech Pty Ltd - www.gobotech.com.au

Please contact Gobotech for any items that are faulty and out of warranty to obtain a quote from our service department to either fix or replace parts where possible.

All carriage, insurance and return charges or duties are the responsibility of the customer and are not covered by the warranty. Grand Lighting products returned under the warranties should be appropriately packaged to prevent damage during transit. Any return of Grand Lighting products under the warranty is done at the sole risk of the customer and Gobotech will not be liable for any damages or losses sustained during transit.