

GRAND LIGHTING™

GL30XHP70_L25 LED GOBO PROJECTOR

Table of Contents 2

INTRODUCTION 3

 Before You Begin 3

 Contents 3

 Safety Information 3

OPERATION 4

 An Overview of Your Light 4

 Installation Guide 4

 Focusing 4

 Rotation 5

 Ensuring Your Light is Water Tight 5

GOBOS 6

 Gobo Specifications 6

 Changing / Installing Your Gobo 6

TECHNICAL SPECIFICATIONS 7

 Photometric Data 7

 Power supply | Light source 7

 Fixture Dimensions 8

SERVICE AND WARRANTY 10

 Standard Warranty 10

 Service, Warranty Claims and Returns 10

BEFORE YOU BEGIN

- Open the contents of the box and check that the goods have not been damaged during transit.

NOTE: You must notify us of any suspected damage within 48 hours upon receiving the goods in order for us to follow up with the freight company.

- Check that you have received the correct goods including projector and gobo (if ordered as a package).
- If you ordered your projector and gobo as a package deal, your gobo should already be installed in the projector ready for use.

Any claims, returns or incorrect supply must be lodged within 48 hours of receiving the goods.

CONTENTS

- GL30 XHP70_L25 IP65 LED Gobo Projector
- External Power Supply
- Gobo (if ordered as a package)
- Manual

SAFETY INFORMATION

Most units will come supplied with a gobo, check to see the projector works for the proposed location before proceeding with the install.

Check the mounting surface is suitable to support the weight of the unit. If a safety cable must be fitted make sure to secure it to the surface mount.

The unit comes supplied with an external driver, the driver is pre set to maximise life span of the LED capsule, do not change the preset values or you will void the warranty.

To avoid losing the driver, do not disconnect it from the unit.

Always disconnect the unit from power when changing the gobo.

WARNING: Do not cover the heat sink or driver with anything as they will need free air flow.

AN OVERVIEW OF YOUR LIGHT

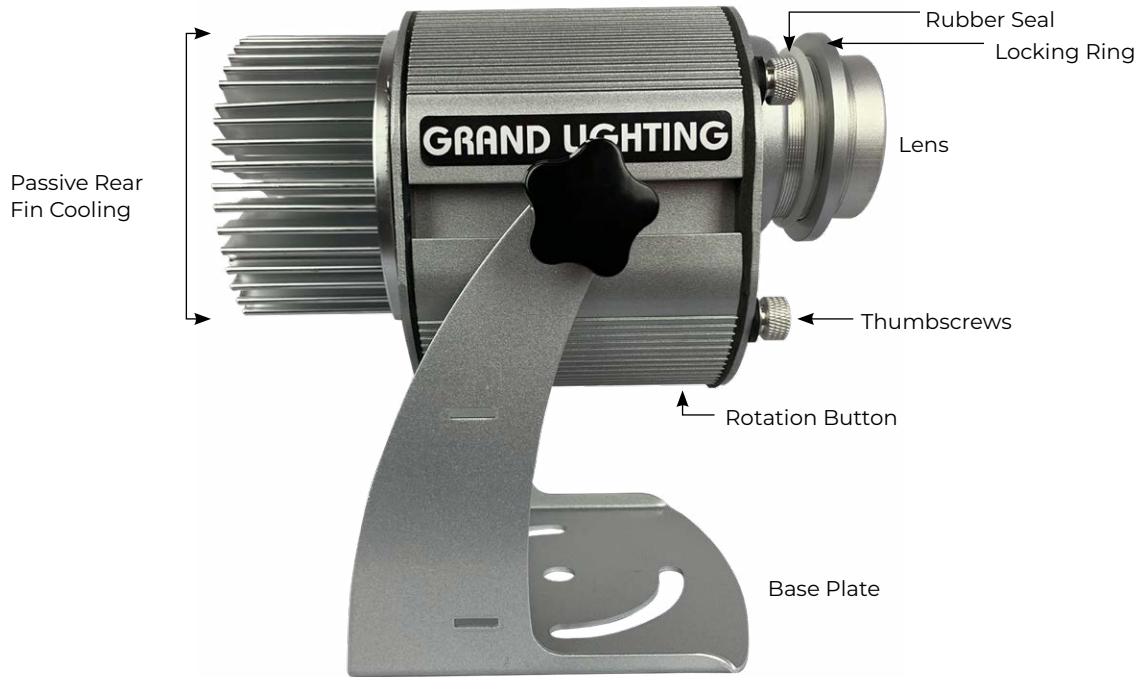

INSTALLATION GUIDE

- The unit is fitted with a preset external power supply, IP65 meanwell driver, and Australian power plug. Input voltage range of 100-240 AC. A qualified electrician can run power directly to the unit or fit a wall outlet to plug the unit into.
- Each unit has a metal base plate with holes suitable for mounting to a fixed point. Once the base is secured, use the locking screws on the side of the unit to point the unit in the appropriate direction, then tighten them firmly.
- It is recommended to fit a safety cable to larger heavier units for additional safety.

FOCUSING

- On the front lens is a rubber seal and locking ring. Loosen this.
- Rotate the front lens in or out until your image is in focus.
- Once you are happy with how the image looks, tighten the locking ring back into place.

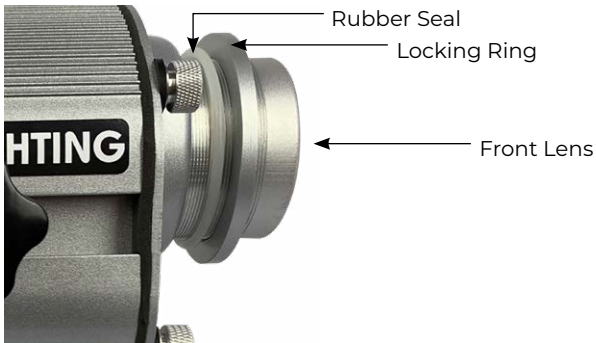

ROTATION

The unit is fitted with a waterproof low voltage switch, which controls the rotation of the gobo. You will find the button below the front facia of the unit.

Press this button to start or stop rotation of the gobo.

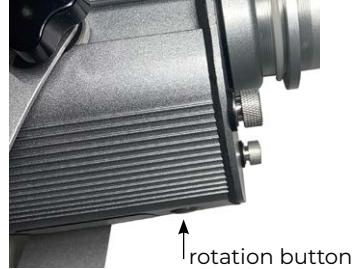

ENSURING YOUR LIGHT IS WATER TIGHT

- If you remove the front lens plate, when replacing, ensure the rubber washers are fitted, then replace the metal washers and finally the thumbscrews. Do them up firm but don't overtighten them (refer image 1a below).
- When you have finished focusing the light, please ensure you tighten the ring to the lamp (refer image 1b below), to ensure it remains at a good focus and is water tight.
- If you do get water inside the unit, it should still function however it is important to make sure all the thumbscrews and locking rings are firmly tightened to avoid water ingress.



image 1a



image 1b

GOBO SPECIFICATIONS

- Suitable material: Metal or Borosilicate glass
- Gobo size: 53.3mm outside diameter +0/-0.3mm
- Maximum image diameter: 25mm
- Maximum thickness: up to 5.0mm

If in doubt please contact Gobotech - www.gobotech.com.au to confirm the gobo specifications for the fixture model you have quoting the serial number.

CHANGING / INSTALLING YOUR GOBO

- To change the gobo, firstly you need to unplug the unit from power.
- Undo the thumbscrews on the front facia (refer image 2a). Be careful not to lose the black rubber seals and the metal washers.
- Carefully remove the front lens plate taking care not to drop it (refer image 2c & 2d).
- There is a circlip that holds the gobo in place, remove this circlip and remove the gobo and donut that is inside (refer image 2d)
- Gently pinch the spring and take care as it can flick out suddenly.
- Replace the gobo and re-insert the circlip ensuring you push it all way down so that the gobo sits flat (refer image 2d).

Glass gobos have a reflective mirror side and a black non reflective or white matt surface. **Glass Gobos are not reversible, they MUST be inserted with the reflective side facing the lamp.** See diagram below showing the order of inserting the gobo into the light.



image 2a



image 2b



image 2c



image 2d

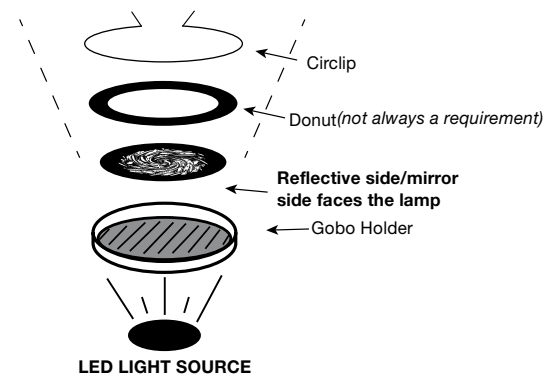

image 2e



image 2f

The reflective / mirror side must face the LED light source



PHOTOMETRIC DATA

Lux values indicated are not peak values, which may be brighter. We give average lux readings taken under actual tests.

	GL30 XHP70_L25				F140 VERY NARROW LENS		
Projection Diameter (m)	0.52	0.61	0.70	0.79	0.87	0.96	1.05
Luminance (lux)	2844	2090	1600	1264	1024	846	711
Projection Distance (m)	3.0	3.5	4.0	4.5	5.0	5.5	6.0

	GL30 XHP70_L25				F100 NARROW LENS		
Projection Diameter (m)	0.68	0.80	0.91	1.03	1.14	1.25	1.37
Luminance (lux)	1707	1250	960	759	614	508	427
Projection Distance (m)	3.0	3.5	4.0	4.5	5.0	5.5	6.0

	GL30 XHP70_L25				F70 MEDIUM LENS		
Projection Diameter (m)	1.00	1.17	1.34	1.51	1.67	1.84	2.01
Luminance (lux)	1013	744	570	450	365	301	253
Projection Distance (m)	3.0	3.5	4.0	4.5	5.0	5.5	6.0

	GL30 XHP70_L25				F56 WIDE LENS		
Projection Diameter (m)	1.33	1.55	1.77	2.00	2.22	2.44	2.66
Luminance (lux)	711	522	400	316	256	212	178
Projection Distance (m)	3.0	3.5	4.0	4.5	5.0	5.5	6.0

**the F56 Wide lens is more suited to breakup gobos*

POWER SUPPLY | LIGHT SOURCE

- Average Power Consumption: 30Watts
- Australian standard 3 pin plug 240V AC
- External power supply IP65 Meanwell HLG-40H-15A: 170mm x 62mm x 38mm
- Input Voltage: 100-240V AC
- 30W CREE XHP (high power) 50,000 hr LED capsule
- Cool White LED standard (unless ordered with Warm White)

FIXTURE DIMENSIONS

- Length: 170mm (excluding lens)
- Length: 250mm (including lens)
- Width: 185mm (with knob)
- Body Height: 130mm
- Height (with Base): 215mm
- Weight: 1.5kg

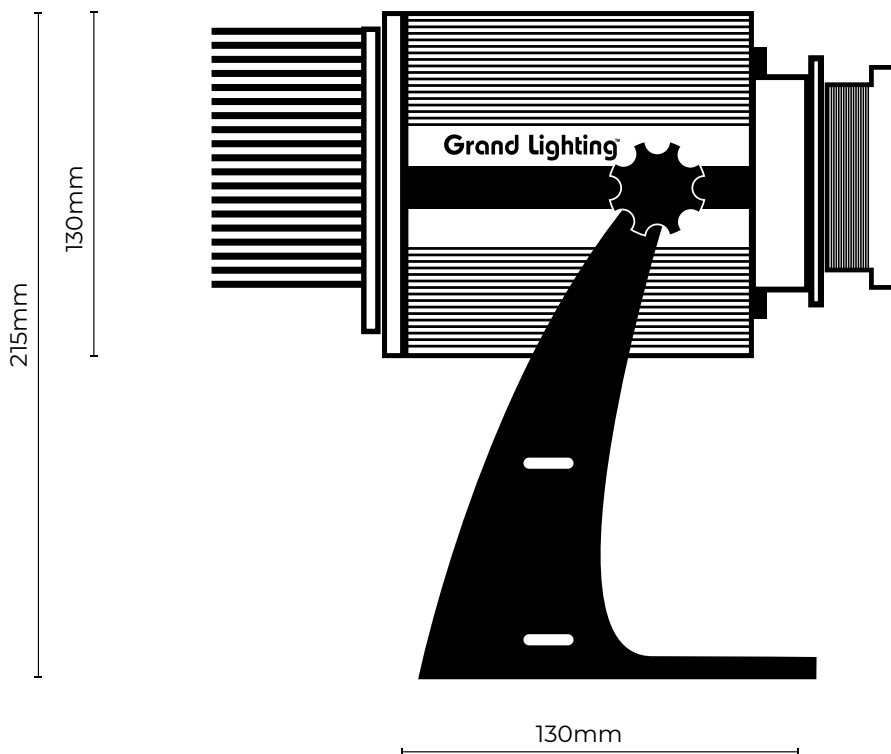
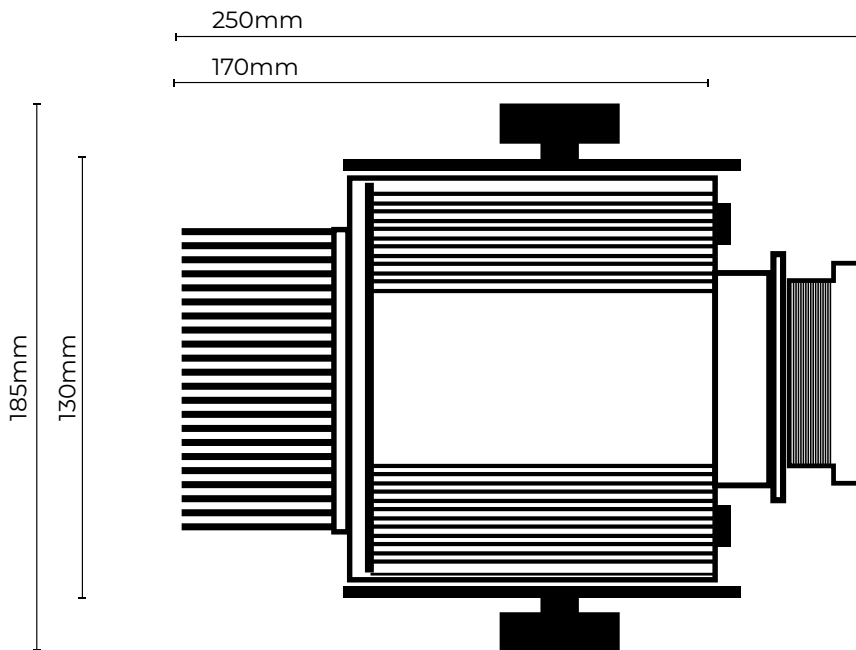

FIXTURE DIMENSIONS

Base Plate

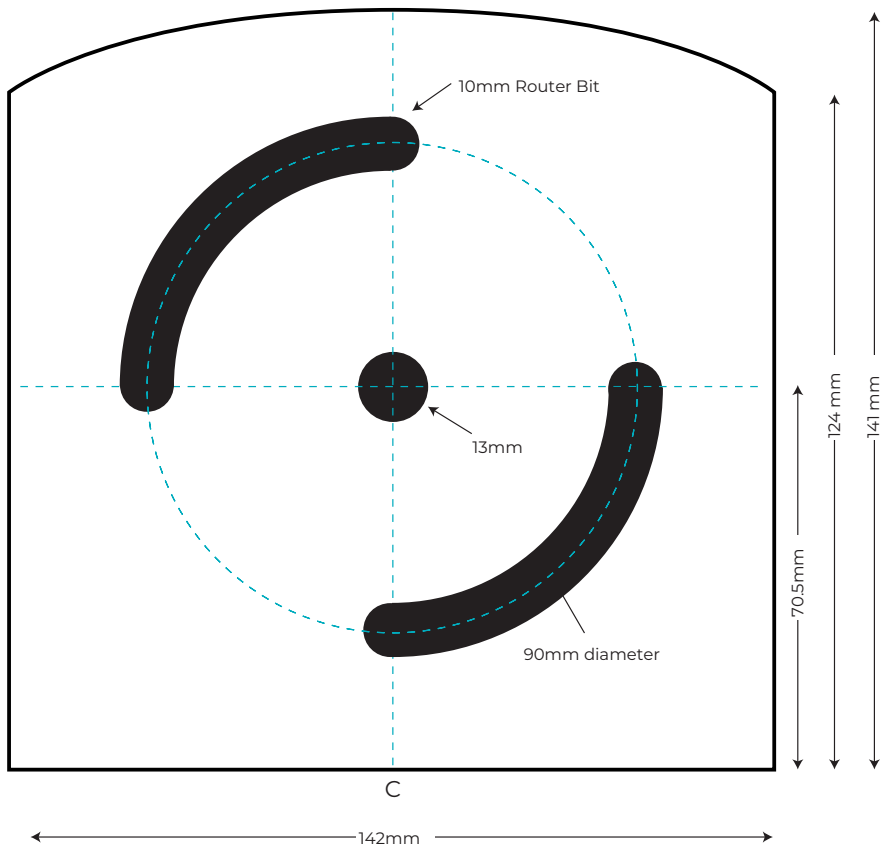

External Power Supply - Meanwell HLG-40H-15A IP65

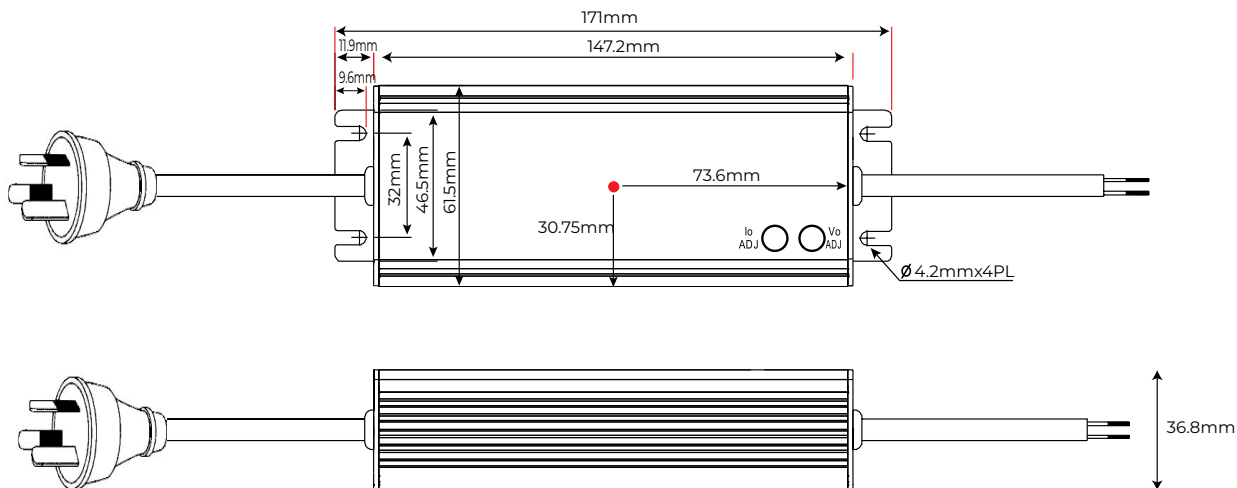

STANDARD WARRANTY

The standard warranty applies only to Grand Lighting products sold by Gobotech Pty Ltd or its authorised resellers, or country distributors. "Standard Warranty Period" means the warranty period applicable under the standard warranty being a period of 24 months from the original date of purchase of the Grand Lighting product(s) unless specifically noted and agreed to otherwise. This warranty also applies to drivers and power supplies that Gobotech have matched and sold with the Grand Lighting product.

Gobotech Pty Ltd or Grand Lighting will not be held responsible for any loss, damage, cost or expense incurred as a result of the installation or removal of any Grand Lighting product for any reason nor does this warranty cover any Grand Lighting product that has become defective due to an accident, act of god, improper installation, power surge, unreasonable use, improper service or unauthorised modification or adjustment of drivers or other causes not arising out of defects in material and workmanship. Normal wear and effects of weather that do not affect the safety or operation of the light are not covered by this warranty.

The warranty provided by us under this document is a "Return to Base" warranty. This means that the product has to be returned to us in order to receive a repair or replacement.

In the event that Grand Lighting is unable to replace or repair any defective Grand Lighting product under the warranty it will use reasonable endeavours to provide an alternative of similar specification and quality. Whilst reasonable endeavours will be taken to match the light quality, LED bin and/or colour temperature of the LED's used for any replacements, it may not always be possible to do so, due to the age of the product, changes in the LED suppliers product specification and availability. In these circumstances Grand Lighting will use reasonable endeavours to offer the closest alternative available.

Replacement parts provided under the warranty are warranted on the same terms and for the remainder of the warranty period of the Grand Lighting products they are replacing or in which they are installed.

Gobotech guarantees that Grand Lighting products are free from defects in materials or workmanship under normal use during the standard warranty period.

During the standard warranty period, Gobotech will, (following prompt written notice of the issue(s) and a reasonable period for investigation) at its discretion, repair or replace either the whole Grand Lighting product or any part of it that Gobotech deems to be defective as a result of a material or manufacturing fault. Gobotech will not be in any way liable under the standard warranty in respect to any Grand Lighting product that:

- 1) Was not originally installed in accordance with:
 - a) The installation instruction supplied with, or printed on, the Grand Lighting product or published on the Grand Lighting website (www.grandlighting.com.au)
 - b) The standards of good practice.
- 2) Was not installed in suitable environmental conditions (including but not limited to ambient temperature, moisture level and air flow for that particular Grand Lighting product;
- 3) Has been altered or modified in any way by third parties not authorised by Gobotech to do so;
- 4) Has been subject to misuse (including but not limited to incorrect operation by the user or connection to or operation with an unsuitable power supply);
- 5) Has been previously repaired by a person other than an authorised representative of Gobotech

The standard warranty period will only be valid if the date of purchase is confirmed by an official invoice issued at the time of purchase.

SERVICE, WARRANTY CLAIMS AND RETURNS

In order to make a claim under the warranty and receive the Return Authorisation Form, please contact:

Gobotech Pty Ltd - www.gobotech.com.au

Please contact Gobotech for any items that are faulty and out of warranty to obtain a quote from our service department to either fix or replace parts where possible.

All carriage, insurance and return charges or duties are the responsibility of the customer and are not covered by the warranty. Grand Lighting products returned under the warranties should be appropriately packaged to prevent damage during transit. Any return of Grand Lighting products under the warranty is done at the sole risk of the customer and Gobotech will not be liable for any damages or losses sustained during transit.